

TNC Card Server

Outline

This guide provides an overview of the TNC Card Server system. Without going into fine details, we describe how the system can be set up, configured and managed.

Overview

TNC Card Server is an access-control system using cards and keypad entry. The system comprises the **Main Controller (TNC-3000)**, the front-end Readers (also known as **Enterprise Card Only Clients**), and the **Door Controller** boards. Figure 1 illustrates the overall system setup.

The Main Controller, TNC-3000, is an embedded controller that can support up to a maximum of 30 Enterprise Card Only Clients. TNC-3000 can communicate with these clients via RS-485 or Ethernet, or a combination of both techniques. We will explore in detail these connectivity options later.

There are 3 types of Enterprise Card Only Clients. They range from the simple one that carries only a card reader, to one that has both a keypad and an LCD screen for user interface. As illustrated in Figure 2, these clients are namely **SOHO Enterprise Card Only**, **Mini Enterprise Card Only** and **Touchstar Enterprise Card Only**. They are also known as **E54**, **E55** and **E56** respectively.

The Door Controller boards come in 2 types. The first type is known as **Robocard-485** which comes with a built-in Ethernet connection. The second type is known as **Door Zone Controller (or DZC)**, which does not have any built-in Ethernet connection. While the main purpose of each board is to perform door control functions, the Ethernet feature in Robocard-485 allows it to additionally act as a Ethernet bridge between the client and TNC-3000. Figure 3 illustrates these 2 different types of Door Controllers.

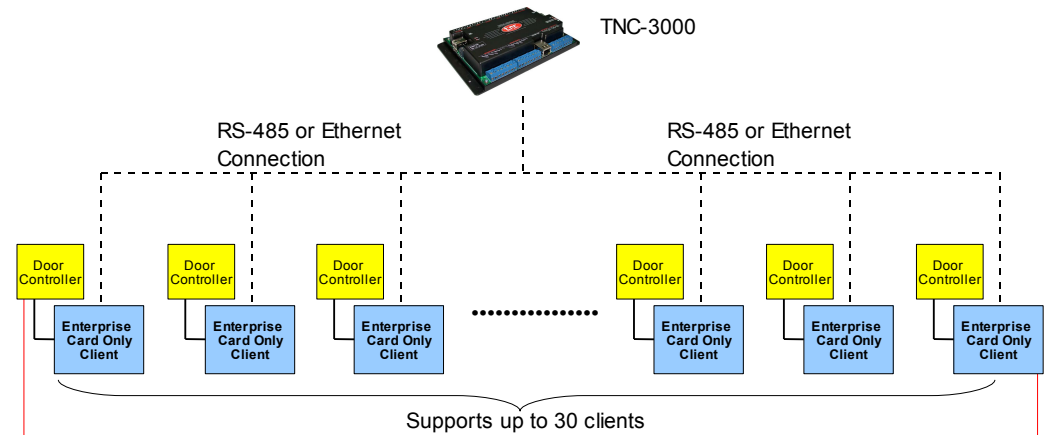

Figure 1 : Overview of TNC Card Server system



Figure 2 : Types of Enterprise Card Only Clients

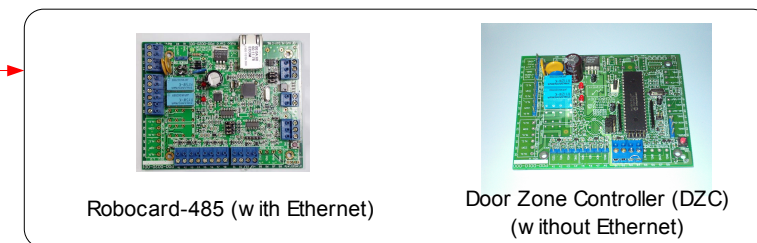

Figure 3 : Types of Door Controller boards

Connectivity Options for Clients

The Enterprise Card Only Clients can be connected to TNC-3000 via a few interesting ways. They can be connected:

- (a) Via RS-485.
- (b) Via Ethernet (TCP/IP).
- (c) Via a combination of both RS-485 and Ethernet.

In this section, we will explore these various methods.

(a) Via RS485

TNC-3000 has 3 RS-485 serial channels. Each channel can support up to 10 Enterprise Card Only Clients. The clients in each port needs to be daisy-chained together.

For door control function, each client can be connected to the Door Zone Controller (DZC) board. Although the Robocard-485 can perform the same function, it is not needed because the Ethernet function on the Robocard-485 is not required in this setup.

How is the client connected to the DZC board ? Each client is wired to the Door Zone Controller via 2 sets of cables. The first set is for the standard Wiegand signaling. The second set is for feedback signal from DZC to the client for ajar monitoring.

Figure 4 illustrates this setup.

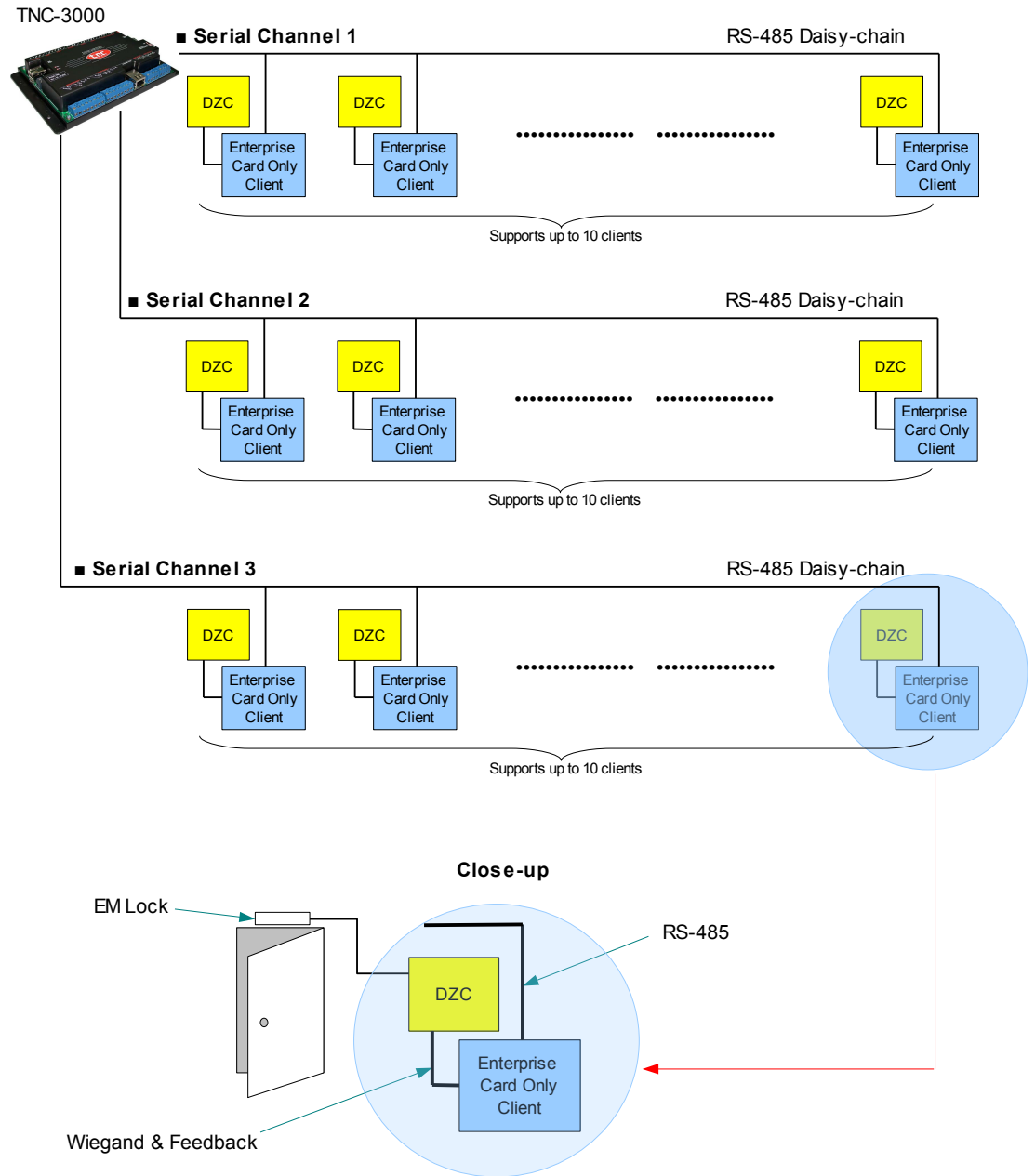

Figure 4: Clients connected to TNC-3000 via the 3 serial RS-485 channels

(b) Via Ethernet (TCP/IP)

In (a), we have seen that the clients can be connected to TNC-3000 via RS-485. If RS-485 wiring is not readily available at an installation site, or if Ethernet connection was already available at the site, you can connect the clients via Ethernet.

In this setup, an Ethernet-to-serial bridge is required. This bridge acts as an Ethernet conduit between a client and TNC-3000. The dual role capability of Robocard-485 allows it to act as this bridge while fulfilling its role as a door controller at the same time.

Figure 5 illustrates this setup.

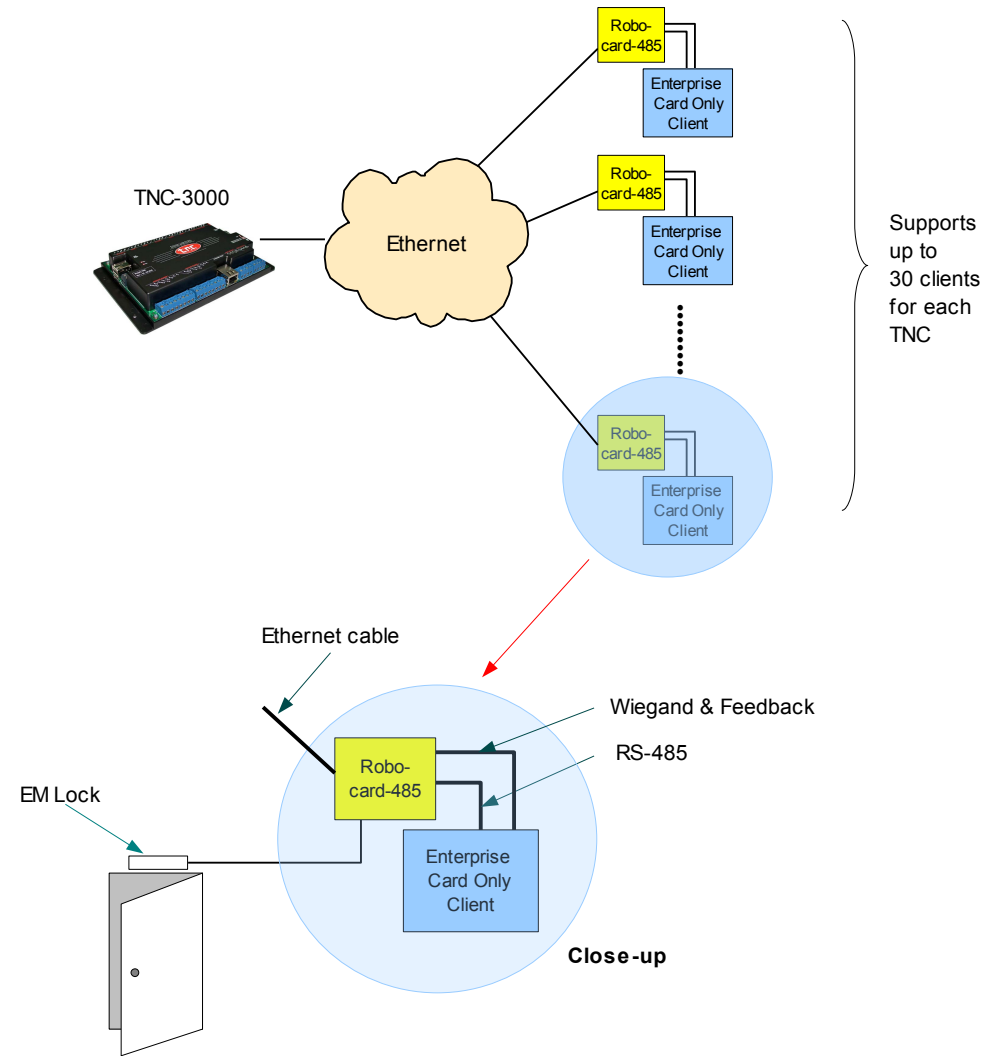

**Figure 5: Clients connected via Ethernet to TNC-3000
(One Robocard-485 to one client)**

(b) Via Ethernet (TCP/IP) - (Cont'd)

You will notice that with above setup in Figure 5, a total of 30 IP addresses, one for each Robocard-485 board is required.

For reasons such as if the number of IP addresses you can obtain are limited, you can modify the setup such that a single Robocard-485 board is bridged out (via RS-485 daisy-chain) to a number of clients. You can connect up to 30 clients via this method of Ethernet-to-serial RS485 bridging.

Notice that in this case, each client would require a DZC to perform the door control function.

Figure 6 illustrates this possibility. For door control function, you will notice that while all other clients use a DZC, the first client makes use of the dual-role Robocard-485.

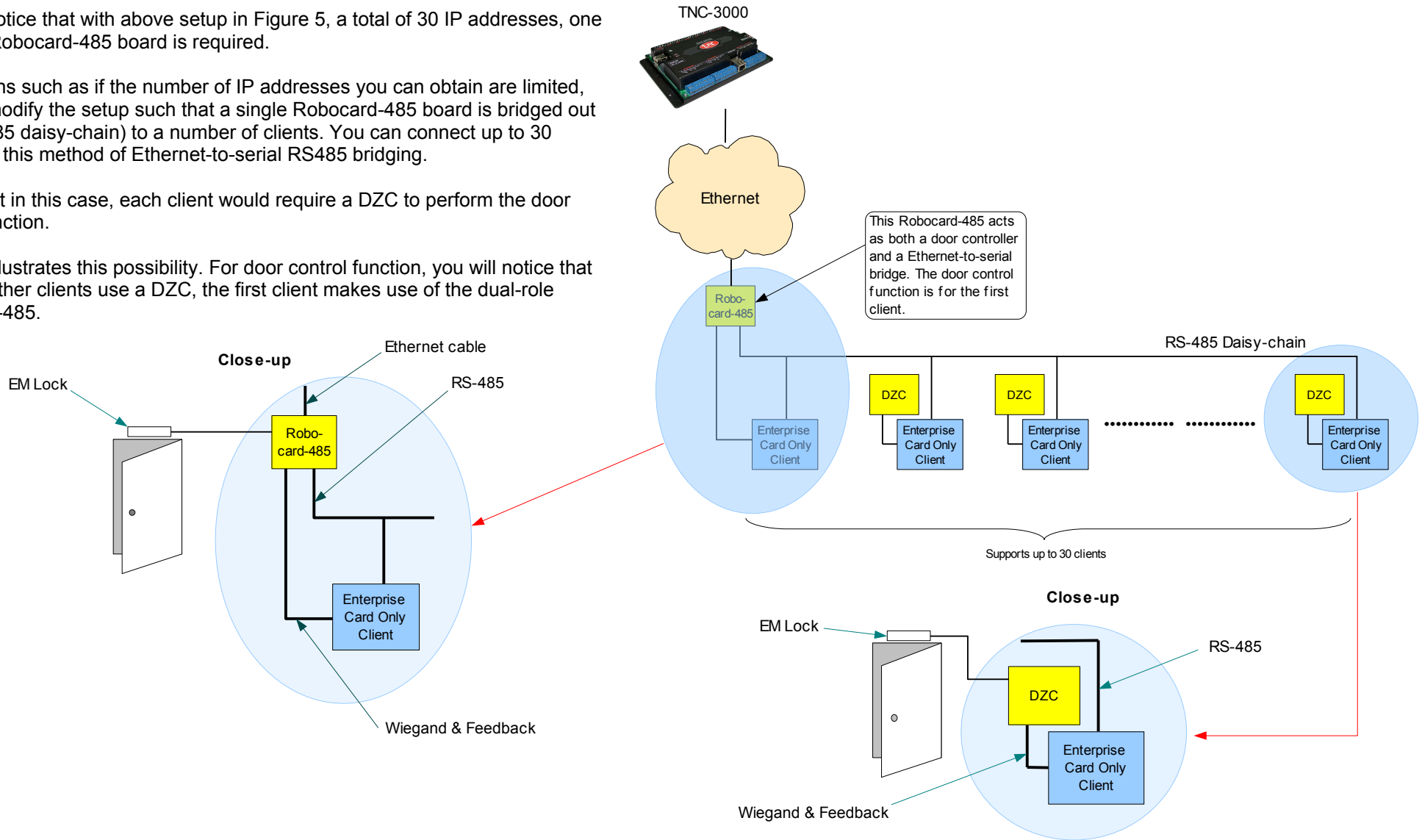

Figure 6: Clients connected via Ethernet but through a bridge (One Robocard-485 to several clients)

(c) Via a combination of both RS-485 and Ethernet (TCP/IP)

Lastly, we will look at a setup where you can mix Enterprise Card Only Clients that are connected via RS-485 and those that are connected via Ethernet.

This setup is illustrated in Figure 7.

In this figure, there are a number of clients which are connected via Ethernet. For these clients, static IP address needs to be assigned to the Robocard-485 boards. At the same time, there are also a number of clients which are connected via RS-485 to a serial channel in TNC-3000. Although the figure has only illustrated one serial channel being used, you can actually use all 3 channels within TNC-3000.

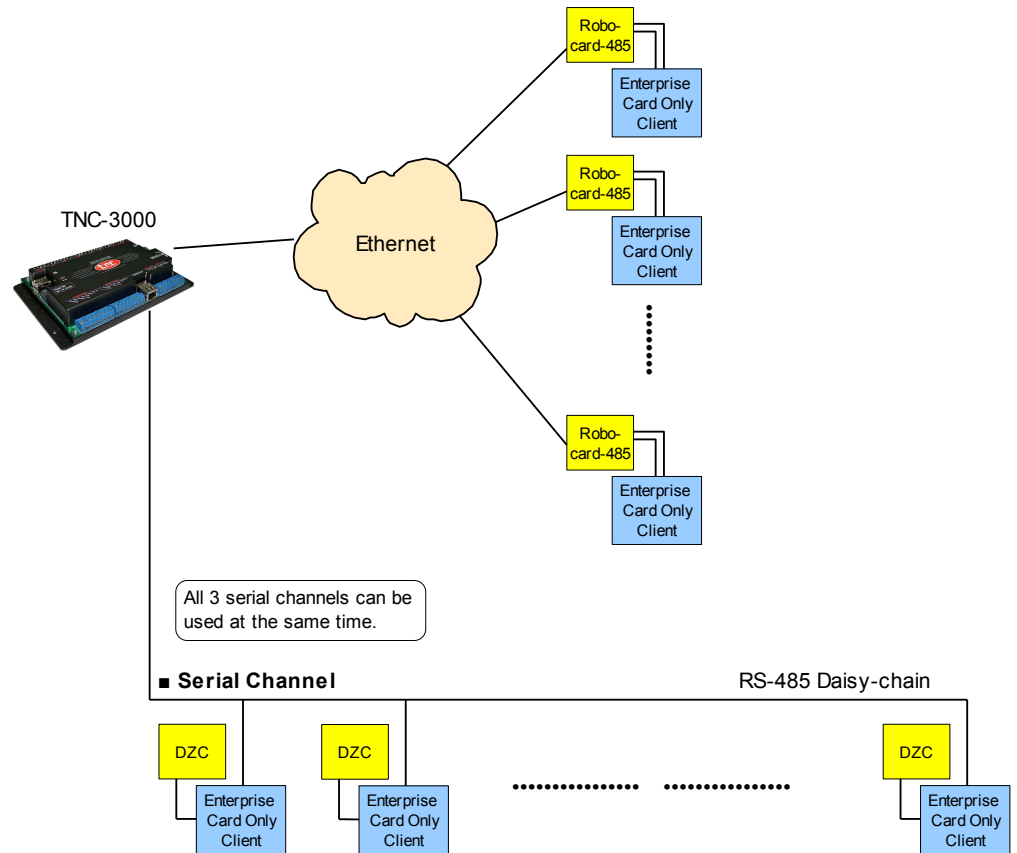

**Figure 7: Clients connected via Ethernet and via RS-485
(Total number of clients to one TNC should not exceed 30)**

Software Configuration & Management

Thus far, we have looked at "connection" diagrams, that is, we have understood how the Enterprise Card Only Clients, the Robocard-485 and DZC boards are connected. In this section, we will look at how to configure the system, and what are the software programs that are available for central management.

(a) Console-based configuration for TNC-3000

TNC Card Server is a flexible and scalable system. It not only allows you to choose the type of clients you need, it also allows you to add on more clients in the future, subject to a maximum of 30 clients to each Main Controller.

Adding (or removing) clients to each Main Controller is performed via a simple console program known as Telnet. Telnet is a basic console utility available in any Windows OS or any other operating system's terminal-based program.

```

Telnet 192.168.0.234
*****
TNC Card Server Config
*****
<<<<< Channel 1 >>>>
Client ID : 1 --- W0000013 IP : 192.168.0.229
Client ID : 2 --- W0000012 IP : 192.168.0.229
Client ID : 3 --- W0000005 IP : 192.168.0.229
Client ID : 4 --- W0000003 IP : 192.168.0.229
Client ID : 5 --- W0000002 IP : 192.168.0.229
Client ID : 6 --- W0000004 IP : 192.168.0.229
Client ID : 7 --- W0000007 IP : 192.168.0.229
Client ID : 8 --- W0000008 IP : 192.168.0.229
Client ID : 9 --- W0000009 IP : 192.168.0.229
Client ID : 10 --- IP :
<<<<< Channel 2 >>>>
Client ID : 11 --- IP :
Client ID : 12 --- IP :
Client ID : 13 --- IP :
Client ID : 14 --- IP :
Client ID : 15 --- IP :
Client ID : 16 --- IP :
Client ID : 17 --- IP :
Client ID : 18 --- IP :
Client ID : 19 --- IP :
<<<<< Channel 3 >>>>
Client ID : 21 --- IP :
Client ID : 22 --- IP :
Client ID : 23 --- IP :
Client ID : 24 --- IP :
Client ID : 25 --- IP :
Client ID : 26 --- IP :
Client ID : 27 --- IP :
Client ID : 28 --- IP :
Client ID : 29 --- IP :
Client ID : 30 --- IP :
*****
Version 1.10
1. Add Device to Channel 1
2. Add Device to Channel 2
3. Add Device to Channel 3
4. Delete Device From Channel 1
5. Delete Device From Channel 2
6. Delete Device From Channel 3
7. Delete All Devices
8. Quit
Select :
    
```

← Telnet program for adding or removing client(s) to each client

```

Telnet 192.168.0.229
*****
TNC Telnet Config
*****
Physical Address : 00:00:60:00:10:00
Version : 7.00
1. Device Parameters
2. Server Parameters
3. Change Password
5. Save And Exit
N. Quit Without Save
Select :
    
```

← Telnet program for configuring Robocard-485

(b) Console-based configuration for Robocard-485

The Robocard-485 boards are shipped from factory with a default IP address. In order to change the IP address in the field, Telnet is also used for Robocard-485.

TDM Express Device Setup module

(c) TDM Express - Central Management Software

TDM Express is the central management software that allows you to manage all the clients in your installation. While the console program described in (a) allows you to add (or remove) clients for each TNC-3000, TDM Express allows you to manage all the available TNC-3000s in your setup.

With TDM Express, you can also enroll the cards and assign access rights to the clients. TDM Express also comes with a Real Time Monitoring module where you can monitor the clients in real time. This allows you to be immediately informed if there is card scan event at the client. The program is also capable of informing you of an door-ajar event at the door, if the door-ajar sensing has been properly wired.

Exception Events				
Device Name	Date	Time	Status	
W0000009	11/21/2008	2:21:55 PM	Door ajar on	
W0000005	11/21/2008	2:21:55 PM	Door ajar on	
W0000009	11/21/2008	2:21:55 PM	Door ajar on, Tamper switch on	
W0000012	11/21/2008	2:21:55 PM	Door ajar on	
W0000013	11/21/2008	2:21:55 PM	Door ajar on	

Attendance/Access Events				
Device Name	User ID/Name	Date	Time	Status
W0000013	1013543164	11/21/2008	2:21:55 PM	Attendance In
W0000013	1013543164	11/21/2008	2:21:57 PM	Attendance In
W0000013	1013543164	11/21/2008	2:21:59 PM	Attendance In
W0000013	1013543164	11/21/2008	2:22:01 PM	Attendance In

← TDM Express Real Time Monitoring module

Figure 8: Software Configuration & Management in TNC Card Server

Basic System Specifications

Up to now, we have looked at the connection diagrams and the software modules that you can use for configuration and management. We will now look at some basic system specifications before concluding this guide.

TNC-3000	
Communication Interface:	
■ Serial RS-485	
■ Ethernet 10/100-Base T	
Storage:	
■ Max Enterprise Card Only Clients supported	30
■ Max users supported	10,000
■ Max transactional log records	100,000

E54 - SOHO Enterprise Card Only Client	
Communication Interface:	
■ Serial RS-485 (Baud rate at 19200 bps)	
■ Wiegand Out	
Others:	
■ Contactless cards supported	HID Proximity & iClass, Mifare, Felica

E55 - Mini Enterprise Card Only Client	
Physical:	
■ Keypad	
Communication Interface:	
■ Serial RS-485 (Baud rate at 19200 bps)	
■ Wiegand Out	
Others:	
■ Contactless cards supported	HID Proximity & iClass, Mifare, Felica

E56 - Touchstar Enterprise Card Only Client	
Physical:	
■ LCD Display	
■ Keypad	
Communication Interface:	
■ Serial RS-485 (Baud rate at 19200 bps)	
■ Wiegand Out	
Others:	
■ Contactless cards supported	HID Proximity & iClass, Mifare, Felica

Robocard-485	
Communication Interface:	
■ Serial RS-485 (Baud rate at 19200 bps)	
■ Ethernet 10-Base T	
■ Wiegand In	

Door Zone Controller	
Communication Interface:	
■ Wiegand In	

Autostar Technology Pte Ltd
Updated: 24 November 2008